

ECONOMICLINE

The Economic Line radiators are made from an aluminium alloy which allows rapid transmission of heat, and due to its anti-corrosion stability, guarantees an almost unlimited lifetime.



**12 year
warranty**

The technological procedure for manufacturing radiators comprises the following phases: die casting, assembly and coating.

The quality is monitored during complete manufacturing process. Quality control begins with the chemical analysis of melting charge and ends with testing of water tightness of both individual columns and complete radiator unit.

The Economic Line radiators are packaged in heat-shrunk protective plastic foil. During the mounting procedure the foil needs to be removed; just break it open at coupling and suspension points. The foil is to be kept in place until end of construction work in order to protect the radiator from dust and possible damage.

Radiator Economic Line is coated with anaforetic basic colour and epoxy-polyester powder. The standard colour is white, RAL 9016, but there is a range of Lipovica colours to chose from.

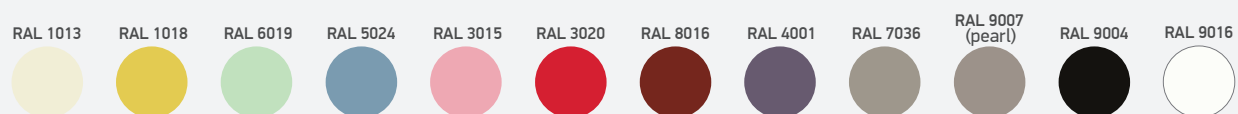

Due to their high quality, good mechanical properties, durability and exceptional resistance to corrosion, Lipovica radiators come with a 12-year guarantee.

The standard at the Lipovica factory is to manufacture high-quality products.

ECONOMICLINE

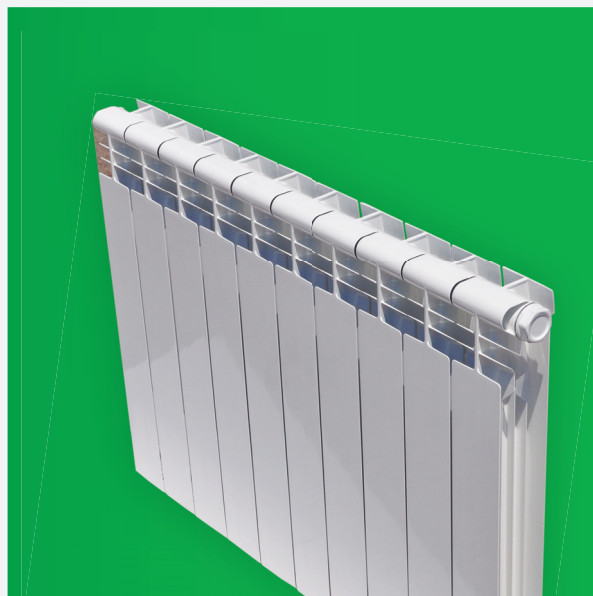

Type of radiator		500/80	600/80
Column high A	mm	576	676
Coupling size B	mm	500	600
Column width C	mm	80	80
Mounting depth D	mm	80	80
Column weight	kg	1,1	1,2
Column water content	l	0,34	0,38
Heating area	m ² /col	0,41	0,45
Heating effect 90/70/20 Δt-60	W/col	123	144
Heating effect 75/65/20 Δt-50	W/col	98	114
Heating effect 55/45/20 Δt-30	W/col	51	59
Radiator coefficient		0,6537	0,73833
Heating effect exponent	n	1,2801	1,2875

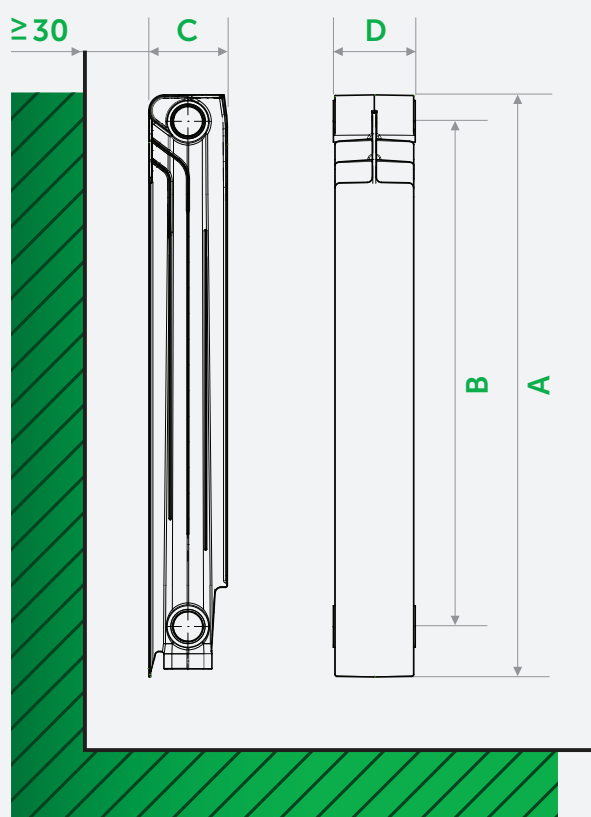

lipovica



LIPOVICA d.o.o.
a company for the production
of aluminium radiators, pressure
casts and gravity casts

Lipovečka 22,
44317 POPOVAČA
OIB: 62434592704
MB: 1686623

RECEPTION

Telephone: +385 (0) 44 569 100
E-mail: lipovica@lipovica.hr

SALES

Telephone: +385 (0) 44 569 130
Facsimile: +385 (0) 44 569 122
E-mail: prodaja@lipovica.hr
Web: www.lipovica.hr